

Through hole tap [THF-1.6 series]

- A chip mounter can be used for this spacer.
- A spacer can be fit on a PC board just by automatically loading it on the PC board and carrying out reflow.
- There is no adsorption film. It can be adsorbed as it is. (Please set the adsorption nozzle dimension according to the external diameter.) (The bottom is closed.)
- Material: Brass
- Finish: Tin plating over nickel base
- Rated current:
 - THF-1.6-□-M220A
 - THF-1.6-□-M2.6.....20A
 - THF-1.6-□-M330A
- Tightening torque:
 - THF-1.6-□-M2.....1.5kgf-cm (14.7N-cm) or less
 - THF-1.6-□-M2.6.....3kgf-cm (29.4N-cm) or less
 - THF-1.6-□-M3.....5kgf-cm (49N-cm) or less
- Adaptive printed board thickness: 1.6t or over
(There is no problem if it is used for other board thickness.)
- Please use the automatic mounter of automatic recognition type.

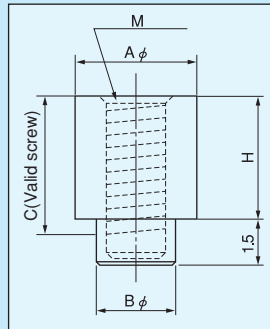

Dimension



Example of usage

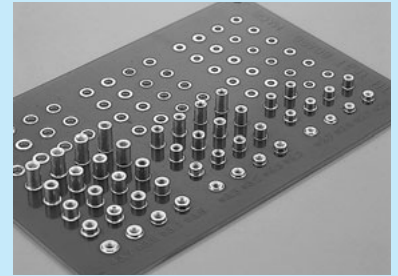

When it is reflowed

Condition of fitting to the PC board

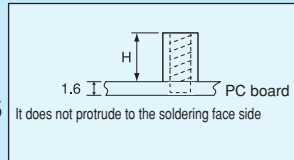

- M2 P=0.4
- M2.6 P=0.45
- M3 P=0.5

To order bulk product

THF-1.6-1.5-M2-B

Please specify -B.

- 100pcs/pack



Condition of fitting the panel to the printed board

Part number

Part number	A	B	C	H	M	Number of taps included in the reel
THF-1.6-1.5-M2	4.0	2.5	1.5	1.5	M2	450pcs
THF-1.6-2.0-M2	4.0	2.5	2.0	2.0	M2	450pcs
THF-1.6-2.5-M2	4.0	2.5	2.5	2.5	M2	350pcs
THF-1.6-3.0-M2	4.0	2.5	3.0	3.0	M2	350pcs
THF-1.6-3.5-M2	4.0	2.5	3.5	3.5	M2	350pcs
THF-1.6-4.0-M2	4.0	2.5	4.0	4.0	M2	250pcs
THF-1.6-4.5-M2	4.0	2.5	4.5	4.5	M2	250pcs
THF-1.6-5.0-M2	4.0	2.5	5.0	5.0	M2	250pcs
THF-1.6-5.5-M2	4.0	2.5	5.5	5.5	M2	350pcs
THF-1.6-6.0-M2	4.0	2.5	6.0	6.0	M2	350pcs
THF-1.6-6.5-M2	4.0	2.5	6.5	6.5	M2	300pcs
THF-1.6-7.0-M2	4.0	2.5	7.0	7.0	M2	300pcs
THF-1.6-7.5-M2	4.0	2.5	7.5	7.5	M2	300pcs
THF-1.6-8.0-M2	4.0	2.5	8.0	8.0	M2	300pcs
THF-1.6-1.5-M2.6	4.5	3.1	1.5	1.5	M2.6	450pcs
THF-1.6-2.0-M2.6	4.5	3.1	2.0	2.0	M2.6	450pcs
THF-1.6-2.5-M2.6	4.5	3.1	2.5	2.5	M2.6	350pcs
THF-1.6-3.0-M2.6	4.5	3.1	3.0	3.0	M2.6	350pcs
THF-1.6-3.5-M2.6	4.5	3.1	3.5	3.5	M2.6	350pcs
THF-1.6-4.0-M2.6	4.5	3.1	4.0	4.0	M2.6	250pcs
THF-1.6-4.5-M2.6	4.5	3.1	4.5	4.5	M2.6	250pcs
THF-1.6-5.0-M2.6	4.5	3.1	5.0	5.0	M2.6	250pcs
THF-1.6-5.5-M2.6	4.5	3.1	5.5	5.5	M2.6	350pcs
THF-1.6-6.0-M2.6	4.5	3.1	6.0	6.0	M2.6	350pcs
THF-1.6-6.5-M2.6	4.5	3.1	6.5	6.5	M2.6	300pcs
THF-1.6-7.0-M2.6	4.5	3.1	7.0	7.0	M2.6	300pcs
THF-1.6-7.5-M2.6	4.5	3.1	7.5	7.5	M2.6	300pcs
THF-1.6-8.0-M2.6	4.5	3.1	8.0	8.0	M2.6	300pcs
THF-1.6-1.5-M3	5.0	3.5	1.5	1.5	M3	450pcs
THF-1.6-2.0-M3	5.0	3.5	2.0	2.0	M3	450pcs
THF-1.6-2.5-M3	5.0	3.5	2.5	2.5	M3	350pcs
THF-1.6-3.0-M3	5.0	3.5	3.0	3.0	M3	350pcs
THF-1.6-3.5-M3	5.0	3.5	3.5	3.5	M3	350pcs
THF-1.6-4.0-M3	5.0	3.5	4.0	4.0	M3	250pcs
THF-1.6-4.5-M3	5.0	3.5	4.5	4.5	M3	250pcs
THF-1.6-5.0-M3	5.0	3.5	5.0	5.0	M3	250pcs
THF-1.6-5.5-M3	5.0	3.5	5.5	5.5	M3	350pcs
THF-1.6-6.0-M3	5.0	3.5	6.0	6.0	M3	350pcs
THF-1.6-6.5-M3	5.0	3.5	6.5	6.5	M3	300pcs
THF-1.6-7.0-M3	5.0	3.5	7.0	7.0	M3	300pcs
THF-1.6-7.5-M3	5.0	3.5	7.5	7.5	M3	300pcs
THF-1.6-8.0-M3	5.0	3.5	8.0	8.0	M3	300pcs
THF-1.6-8.5-M3	5.0	3.5	8.5	8.5	M3	250pcs
THF-1.6-9.0-M3	5.0	3.5	9.0	9.0	M3	250pcs
THF-1.6-9.5-M3	5.0	3.5	9.5	9.5	M3	250pcs
THF-1.6-10-M3	5.0	3.5	10	10	M3	250pcs

Recommended fitting land

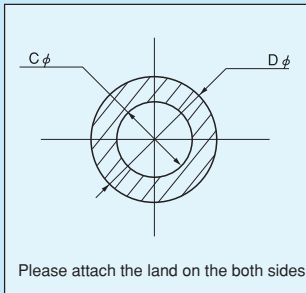

Part number	ϕC	ϕD
THF-1.6-□-M2	2.7	5.0
THF-1.6-□-M2.6	3.3	5.5
THF-1.6-□-M3	3.7	6.0

Recommended metal mask

(Recommended metal mask thickness: 150 μ to 200 μ)

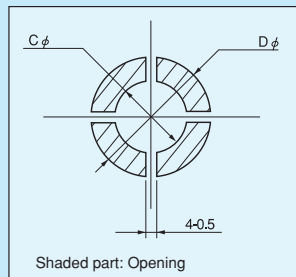

Part number	ϕC	ϕD
THF-1.6-□-M2	2.7	5.0
THF-1.6-□-M2.6	3.3	5.5
THF-1.6-□-M3	3.7	6.0

▲ Use of a through hole tap is limited to a through hole board.
(It is impossible to use it for a one-sided board and non through hole board.)

Dimension of the through hole tap reel [THF-1.6 series]

■ Dimension of the reel (THF-1.6-1.5 to THF-1.6-5.0)

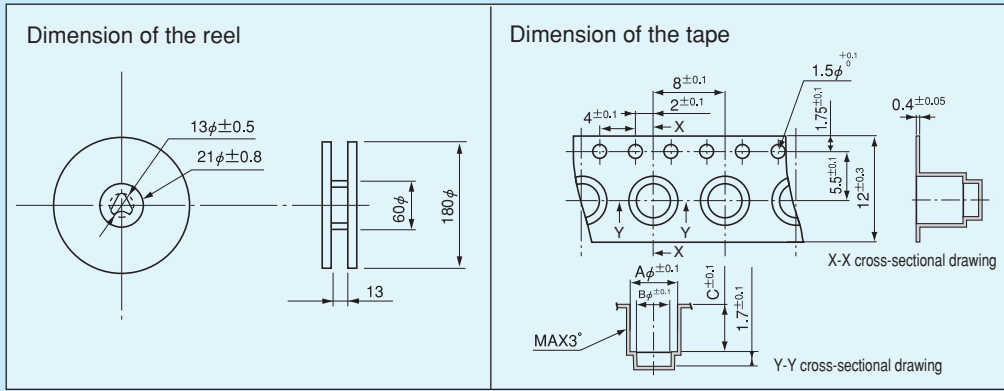

	C
THF-1.6-1.5 to 2.0	2.3
THF-1.6-2.5 to 3.5	3.8
THF-1.6-4.0 to 5.0	5.3

	A	B
M2 Type	4.3	2.8
M2.6 Type	4.8	3.4
M3 Type	5.3	3.8

■ Dimension of the reel (THF-1.6-5.5 to THF-1.6-10)

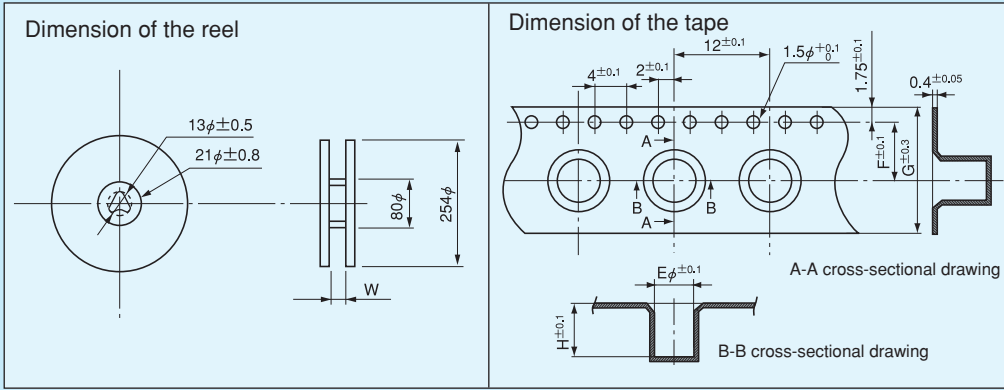

	H	W
THF-1.6-5.5 to 6.0	7.8	17.5
THF-1.6-6.5 to 7.0	8.8	17.5
THF-1.6-7.5 to 8.0	9.8	17.5
THF-1.6-8.5 to 9.0	10.8	17.5
THF-1.6-9.5 to 10	11.8	25.5

	E	F	G
M2.6 Type	4.8	7.5	16
M3 Type (5.5 to 9.0)	5.3	7.5	16
M3 Type (9.5 to 10)	5.3	11.5	24

■ Dimension of the reel (THF-1.6-6.0-M2 to THF-1.6-8.0-M2)

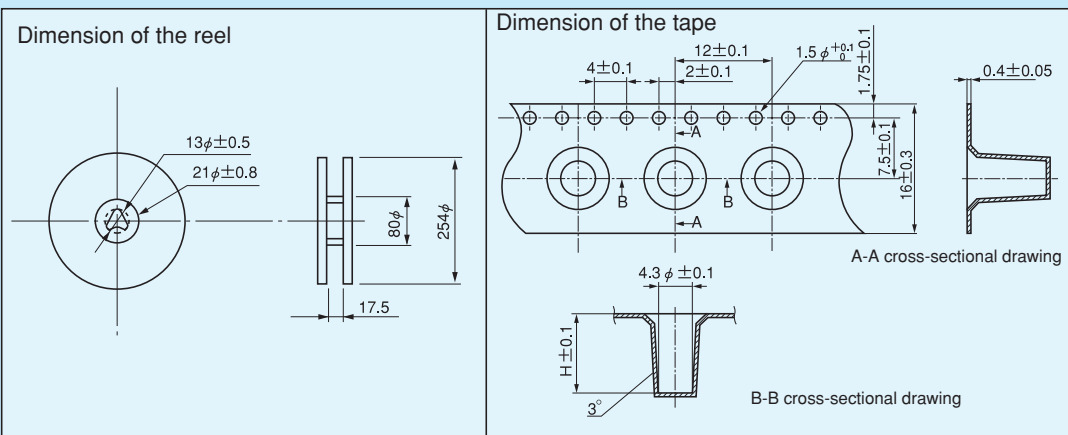

	H
THF-1.6-5.5-M2	7.8
THF-1.6-6.0-M2	7.8
THF-1.6-6.5-M2	8.8
THF-1.6-7.0-M2	8.8
THF-1.6-7.5-M2	9.8
THF-1.6-8.0-M2	9.8

For surface mounting